

K

◆		K-Chargepump	AW8736		
◆		92%			K
◆		75%			
◆		0.02%	K-Chargepump		92%
◆				75%	
◆		0.8W 1W 1.2W	0.02%		
◆					
◆	TDD-Noise		AW8736	K-Chargepump	
◆	EMI				
◆				3.3V-4.35V	
◆	PSRR -65dB 217Hz				
◆	2mm×2mm FC-16		AW8736	0.8W 1W 1.2W	
				0.7W	
			AW8736		TDD-Noise
◆			EMI		TDD-Noise EMI
			AW8736		
					AW8736
					2mm× 2mm FC-16

AW8736FCR TOP VIEW

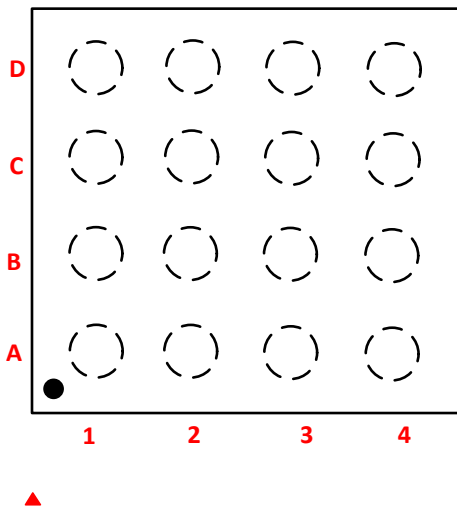

AW8736FCR MARKING

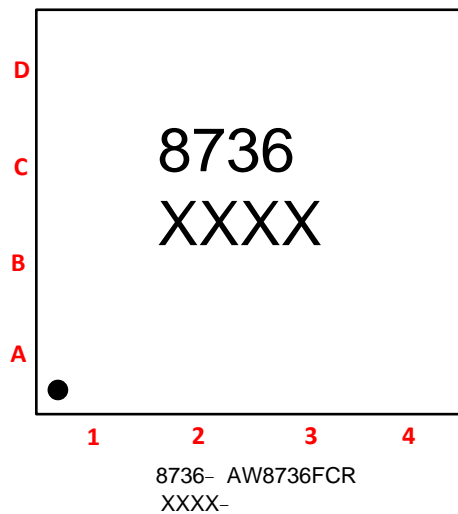

1 AW8736FCR

K

A1	INP	
A2	INN	
A3	VDD	
A4	SHDN	
B1	C2N	Flying C2
B2		
B3		
B4	VOP	
C1	C1N	Flying C1
C2	GND	
C3		
C4		
D1	C2P	Flying C2
D2	C1P	Flying C1
D3	PVDD	
D4	VON	

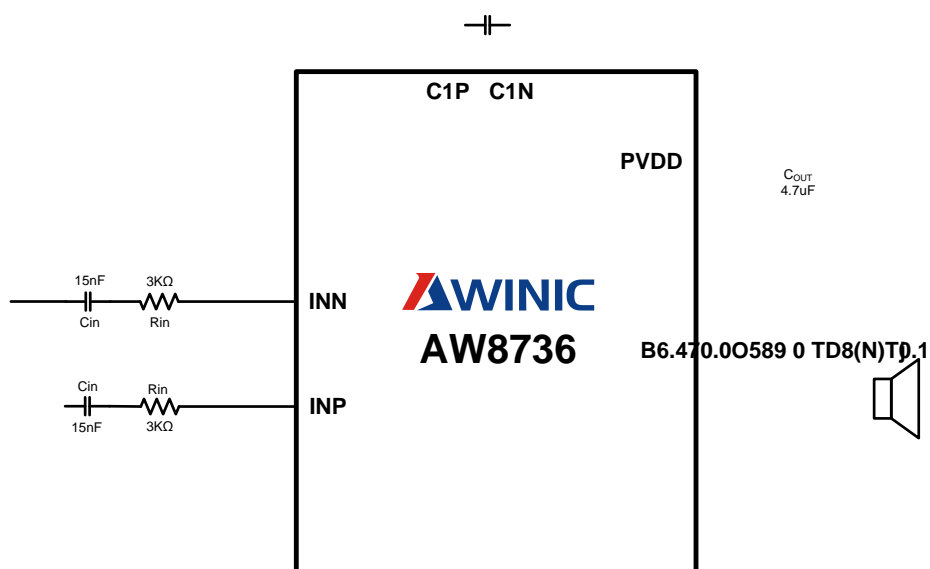

2 AW8736

(1)

1: INN INP

K

Cs X7R/X5R VDD 1uF

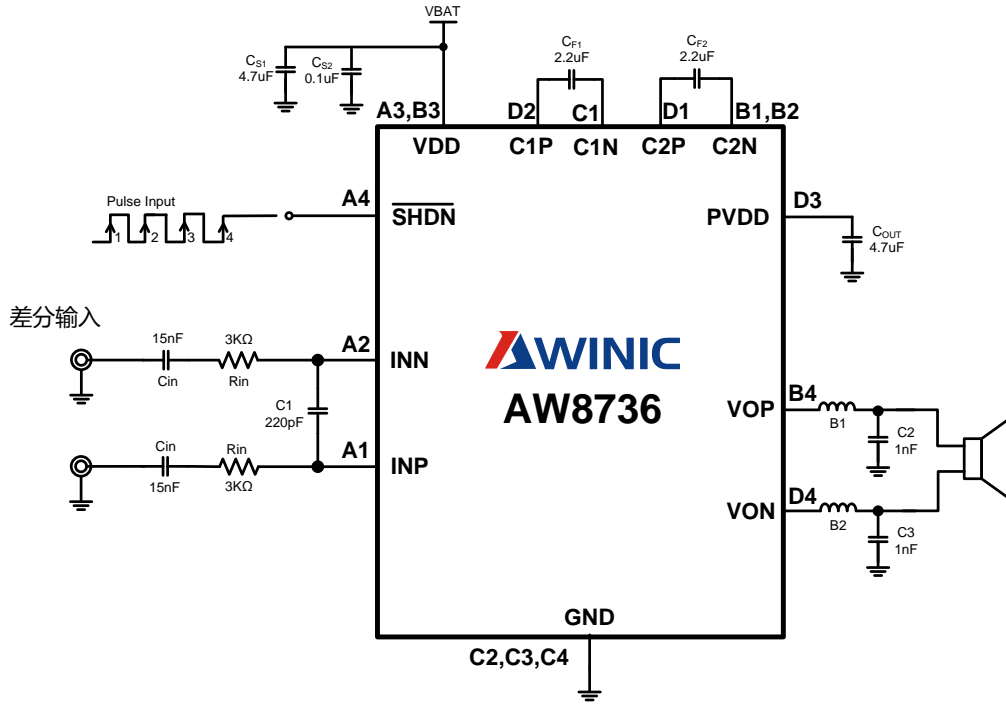

3 AW8736

K

(2)

V _{DD}		
INP INN		
JA		
T _{JMAX}		
T _{STG}		
10		
ESD	3	
HBM		±6KV
Latch-up		
JEDEC STANDARD NO.78B DECEMBER 2008		+IT 450mA -IT -450mA

2:

3: HBM





100pF

MIL-STD-883G Method 3015.7

AW8736 C_{in} R_{in} 16.5K
320K/(R_{in}+16.5K)

1 C_{in}=15nF R_{in}=3K 16.3V/V

2 C_{in}=15nF R_{in}=10K 12V/V

		V/V		NCN		W	NCN
				RL=8Ω	RL=4Ω		
1		16.3	12	1.2	2.25		
2		16.3	12	1	2		
3		16.3	12	0.8	1.6		
4		16.3	12	1.65W@THD=1%	2.15W@THD=1%		

K

T_A=25

V _{DD}			3.0		5.0	V
V _{IH}	$\overline{\text{SHDN}}$		1.3		V _{DD}	V
V _{IL}	$\overline{\text{SHDN}}$		0		0.35	V
V _{OS}		V _{DD} =3.0V to 5.0V	-30	0	30	mV
I _{SD}		V _{DD} =3.6V $\overline{\text{SHDN}}$ =0V			1	
T _{TG}	Thermal AGC			150		
T _{TGR}	Thermal AGC			130		
T _{SD}				160		
T _{SDR}				130		
T _{ON}				40		ms
K-Chargepump						
PVDD		V _{DD} =3.0V to 3.8V		1.5*		V
		V _{DD} >3.8V		5.8		V
V _{hys}	OVP	V _{DD} >3.8V		50		mV
F _{CP}		V _{DD} =3.0V to 5.0V	0.8	1.06	1.33	MHz
CP		V _{DD} =4.2V I _{load} =200mA		92		%
T _{ST}		COU _T =4.7uF	1	1.2	1.4	ms
I _L	PVDD			350		mA
K 1-4						
I _q		V _{DD} =3.6V		9.5		mA
		V _{DD} =4.2V P _o =1.2W R _L		75		%
F _{osc}		V _{DD} =3.0V to 5.0V	600	800	1000	kHz
A _v				16.3		V/V
R _{ini}				16.5		
P _{ncn}	1 NCN	V _{DD} =4.2V R _L		1.2		W
		V _{DD} =4.2V R _L =4		2.25		W
	2 NCN	V _{DD} =4.2V R _L		1		W
		V _{DD} =4.2V R _L =4		2		W
	3 NCN	V _{DD} =4.2V R _L		0.8		W
		V _{DD} =4.2V R _L =4		1.6		W
PSRR		V _{DD} =4.2V V _{p-p_sin} =200mV	217Hz	-53	-65	dB
			1kHz	-53	-65	dB
SNR		V _{DD} =4.2V P _o =0.8W R _L		84.5		dB

K

		$V_{DD}=4.2V$ $P_o=1.65W$ R_L		87.5		dB	
V_n		$V_{DD}=4.2V$ $f=20Hz$ to $20kHz$ input ac grounded	A-weighting	155		μV_{rms}	
THD+N	+	$V_{DD}=4.2V, P_o=1W, R_L$, $f=1kHz, Mode1$		0.02		%	
		$V_{DD}=4.2V, P_o=1.2W, R_L$, $f=1kHz, Mode4$		0.02		%	
P_o	4	THD+N=10% $f=1kHz$ R_L $V_{DD}=4.2V$		2.0		W	
		THD+N=1% $f=1kHz$ R_L $V_{DD}=4.2V$		1.65		W	
		THD+N=10% $f=1kHz$ R_L $V_{DD}=3.6V$		1.5		W	
		THD+N=1% $f=1kHz$ R_L $V_{DD}=3.6V$		1.23		W	
		THD+N=10% $f=1kHz$ $R_L=4$ $V_{DD}=4.2V$		2.58		W	
		THD+N=1% $f=1kHz$ $R_L=4$ $V_{DD}=4.2V$		2.15		W	
		THD+N=10% $f=1kHz$ $R_L=4$ $V_{DD}=3.6V$		1.85		W	
		THD+N=1% $f=1kHz$ $R_L=4$ $V_{DD}=3.6V$		1.55		W	
T_H	\overline{SHDN}	$V_{DD}=3.0V$ to $5.0V$		0.75	2	10	us
T_L	\overline{SHDN}	$V_{DD}=3.0V$ to $5.0V$		0.75	2	10	us
T_{LATCH}	\overline{SHDN}	$V_{DD}=3.0V$ to $5.0V$		150		500	us
T_{OFF}	\overline{SHDN}	$V_{DD}=3.0V$ to $5.0V$		150		500	us
NCN 4							
T_{AT}	(13.5dB)			40			ms
T_{RL}	13.5dB			1.2			s
A_{MAX}				-13.5			dB

4: 13.5dB 13.5dB

AW8736

4

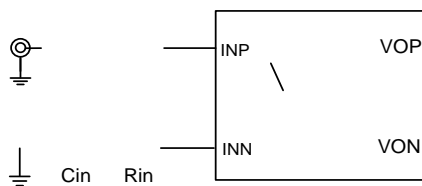

4 AW8736

K

1

500	10nF	32kHz
1k	4.7nF	

K

K

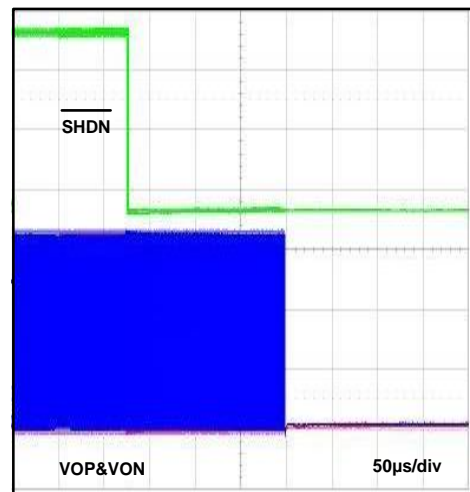
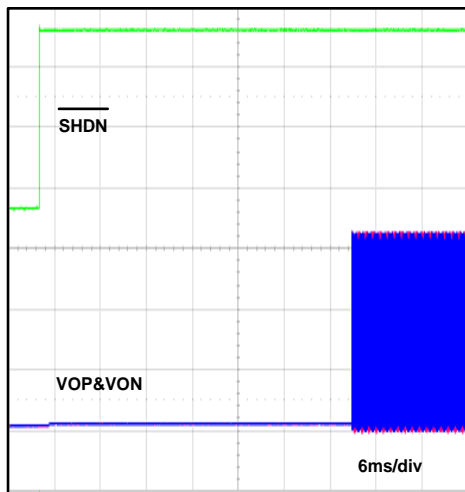
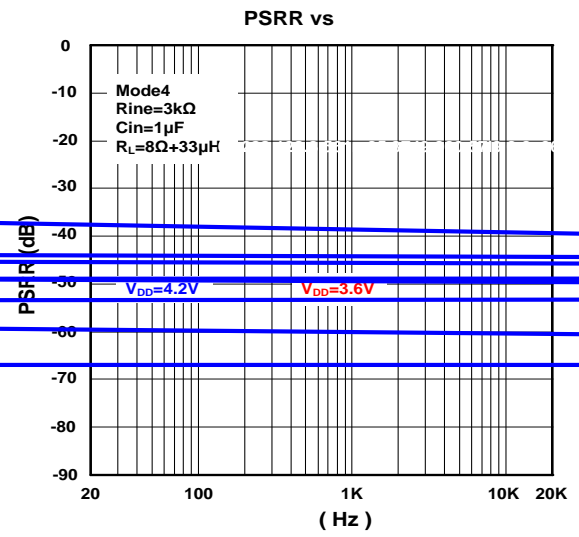
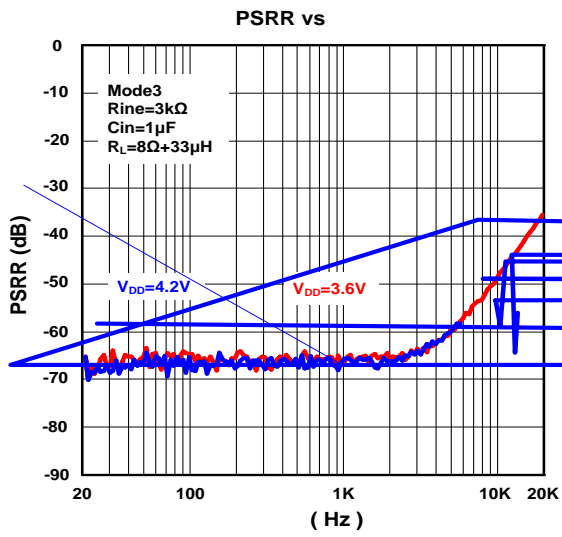

K

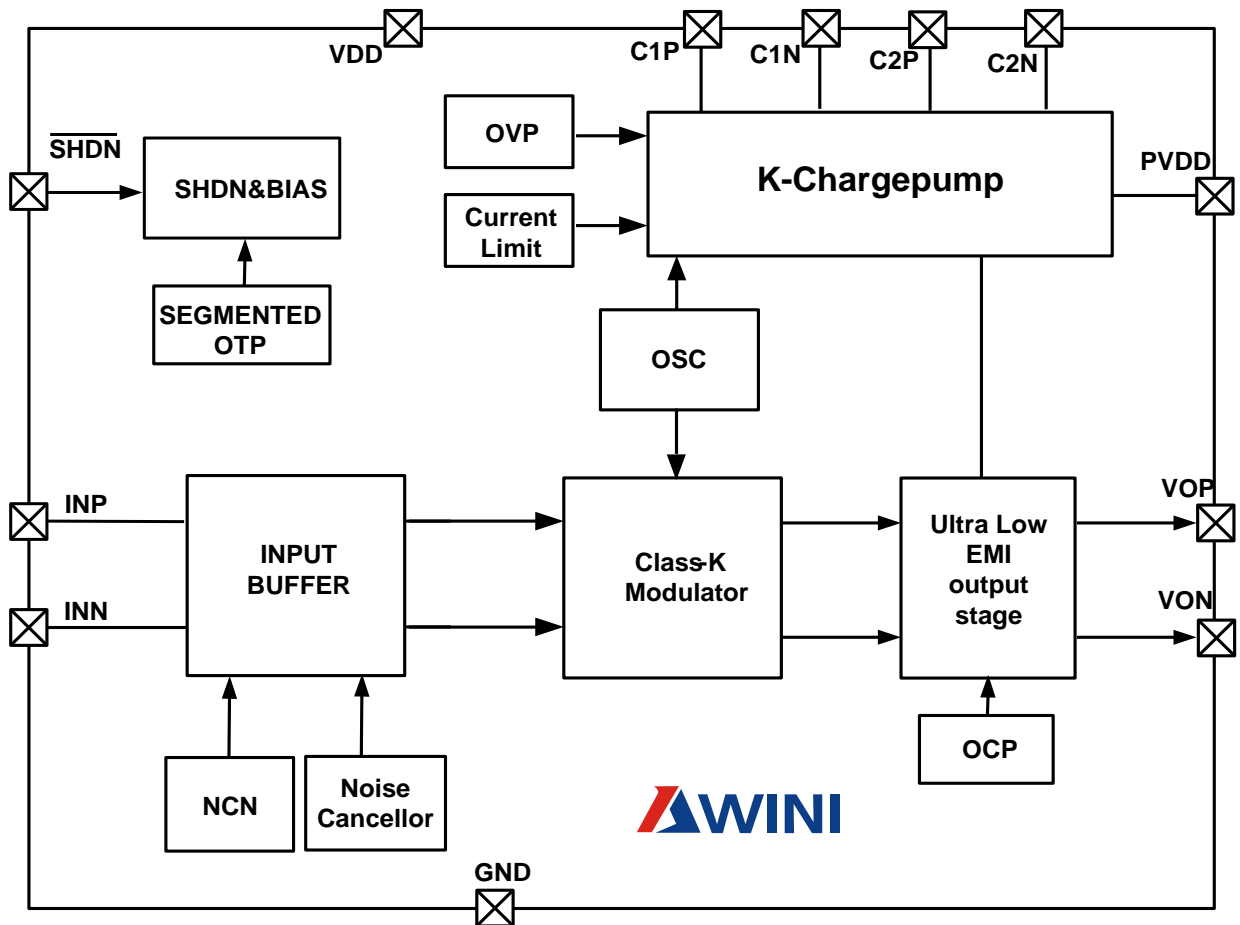
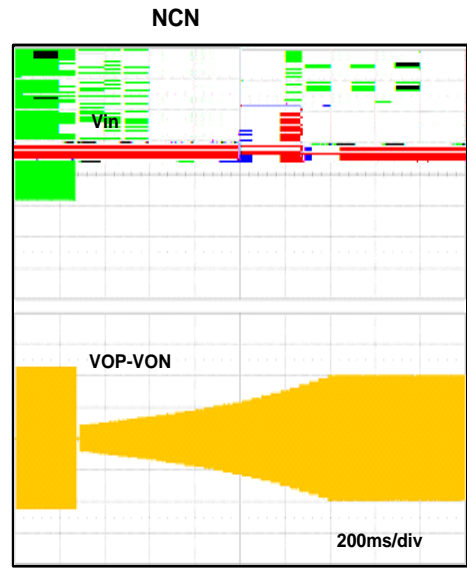
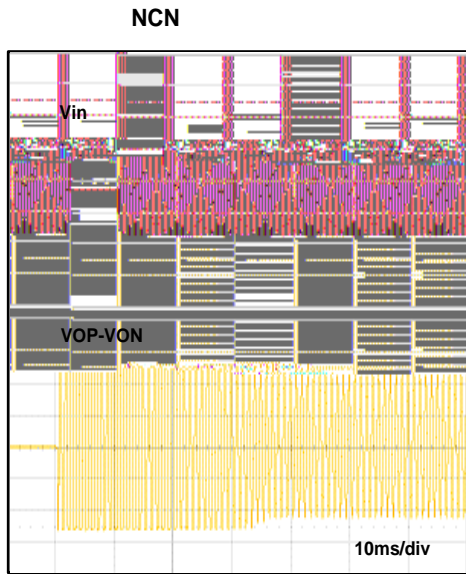

K

AW8736									K
			K-Chargepump						(OVP)
	92%		75%			0.02%			
AW8736			K-Chargepump						
	3.3V-4.35V						AW8736	0.8W	1W
1.2W			0.7W						
AW8736		TDD-Noise	EMI				TDD-Noise	EMI	
AW8736							AW8736		2mmx2mm
FC-16		-40	85						
			NCN						
AW8736			NCN			3.3V~4.35V			NCN
									AW8736
			AW8736	4					NCN
	1.2W	1W	0.8W						
NCN(Non-Crack-Noise)									
									NCN
									NCN
									7

K

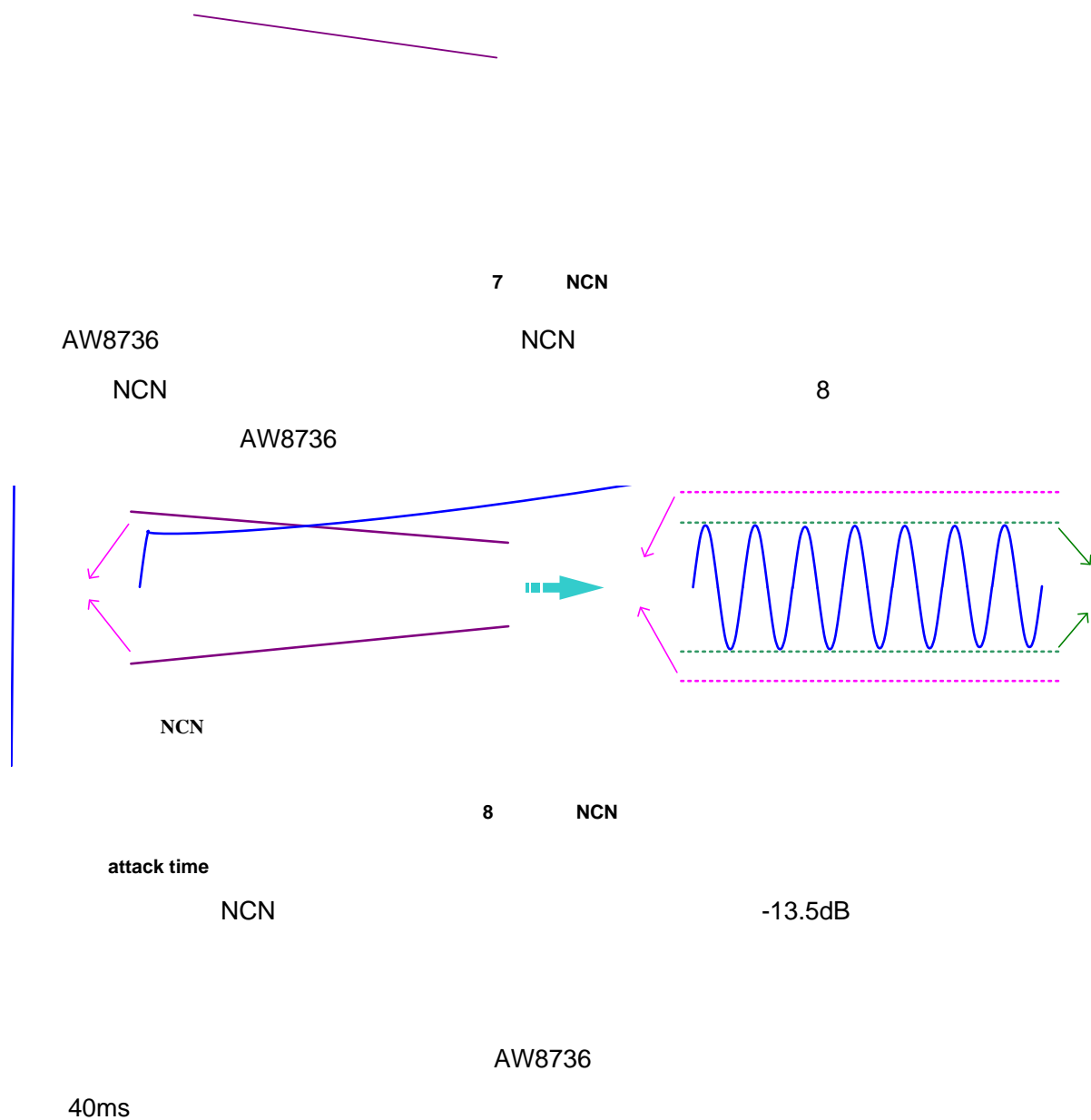

K

release time

NCN

AW8736

1.2s

K-Chargepump

AW8736 K-chargepump

1.1MHz,

AW8736 K-chargepump PVDD VDD 1.5
100% K-chargepump

$$\eta = \frac{P_{OUT}}{P_{IN}} * 100\%$$

M K-chargepump I_{IN} I_{OUT} M

$$\eta = \frac{P_{OUT}}{P_{IN}} * 100\% = \frac{V_{OUT} * I_{OUT}}{V_{IN} * M * I_{OUT}} * 100\% = \frac{V_{OUT}}{M * V_{IN}} * 100\%$$

M (1.5), V_{OUT} V_{IN} I_{OUT}
K-chargepump 1.5 100%
IC 92% K-chargepump

9 AW8736 7 7
PVDD VDD 1.5

K

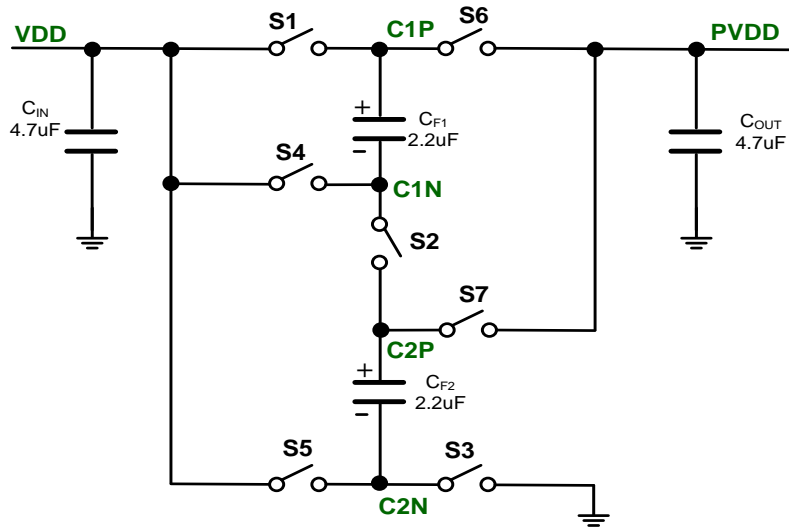

9

10 S1 S2 S3 VDD Flying

C_{F1} C_{F2}

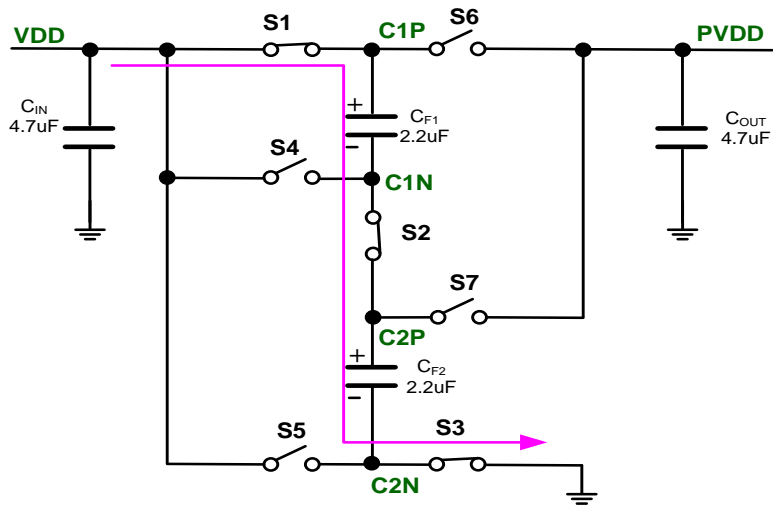

10 Φ1 Flying

11 S1 S2 S3 S4 S5 S6 S7
Flying C_{F1} C_{F2} VDD PVDD

K

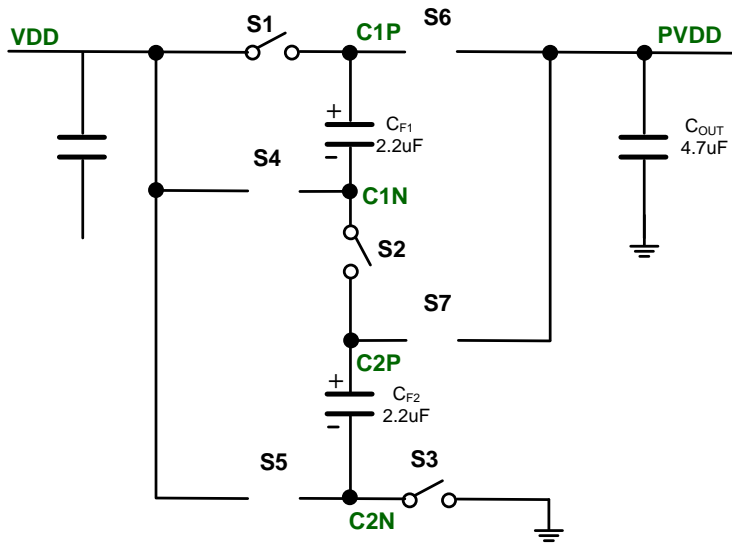

11 Φ2 Flying

C_{OUT}

K-chargepump

350mA

1.2ms

K-chargepump

1.5A

(OVP)

K-chargepump

PVDD

VDD

1.5

K

K-chargepump

VDD

3.8V

PVDD

VDD

PVDD

5.8V

50mV

GPIO

GPIO

Deglitch

12

K

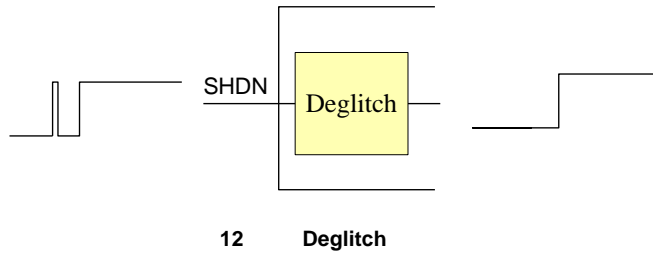

BB

AW8736

13

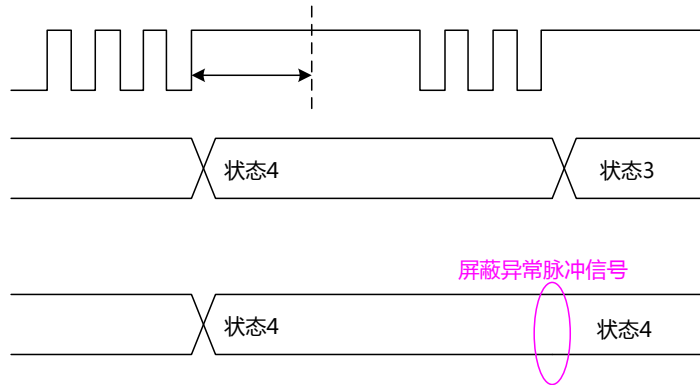

13

AW8736

SHDN

14

SHDN

AW8736

1 SHDN

AW8736

AW8736 4

4

K

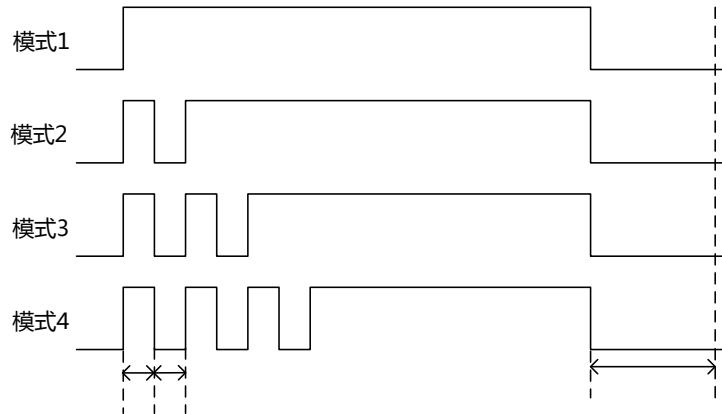

14

SHDN

1ms

T_{OFF}

15

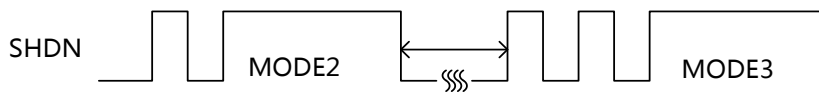

15

RNS(RF TDD Noise Suppression)

TDD Noise

GSM	TDMA	Time Division Multiple Access()	
	TDMA	8		4.615ms
		0.577ms		
GSM	RF	4.615ms	217Hz	
Burst		Burst	217Hz	900MHz
1800MHz	RF	217Hz	217Hz	
		217Hz		
TDD Noise		217Hz	217Hz	

K

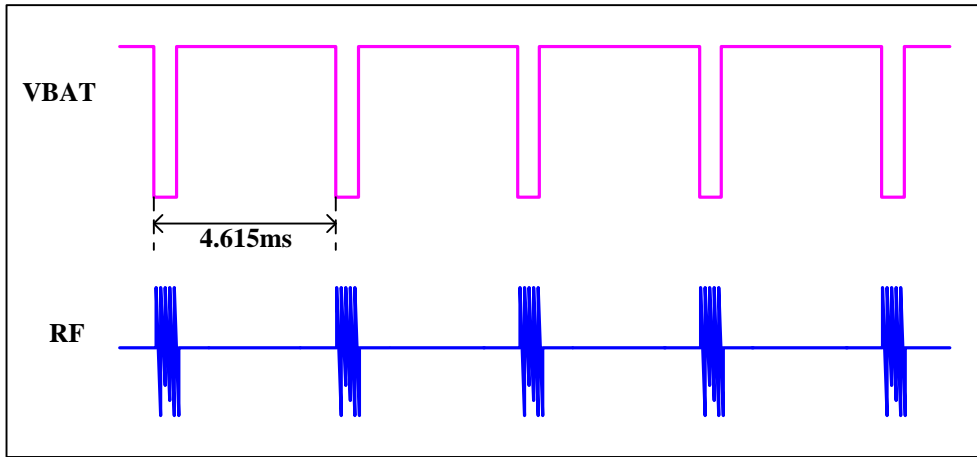

16 GSM

RF

RNS

TDD

Noise

RF

217Hz

217Hz

PSRR

$$PSRR = 20 \log \left(\frac{v_{out_{ac}}}{v_{dd_{ac}}} \right)$$

PSRR

-60dB -60dB

1000

500mVp

0.5mV

PSRR

-60dB

-80dB

TDD Noise

Rin

Cin

PSRR

24

1%

PSRR

-46dB

10%

PSRR

-28dB

TDD Noise

K

PSRR AW8736
10% PSRR
RF
RF
PCB RF
RF
RF
PCB RF
TDD Noise AW8736
RF
RF
Noise RF TDD

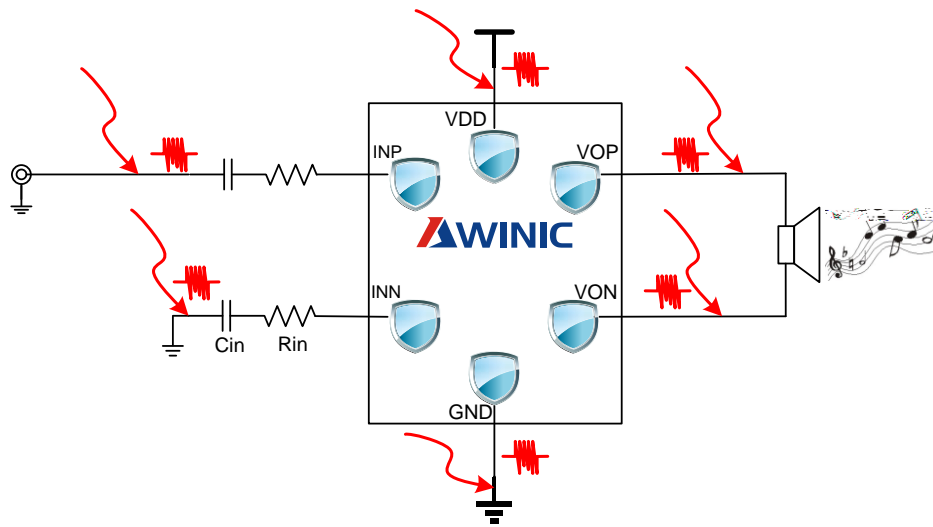

17 RF

D
D
LC PCB LC THD+N

K

AW8736

D

LC

VOP VON

VOP

VON

EEE

AW8736

EEE

EMI

FCC CLASS B

Pop-Click

Pop-Click

AW8736

Pop-Click

Thermal AGC/

AW8736

Thermal AGC

AW8736

Thermal AGC

150

130

160

130

AW8736

AW8736

AW8736

K

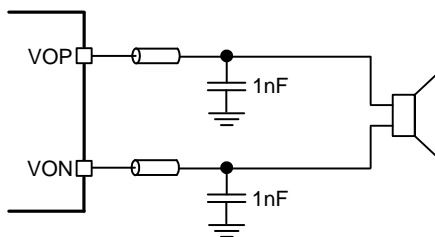

18

Sunlord	UPZ1608U221-2R2TF	0603	$I_{max}=2.2A; Z@100MHz=220 \Omega; DCR=0.05$	8Ω
---------	-------------------	------	---	------------

K

1nF

PCB

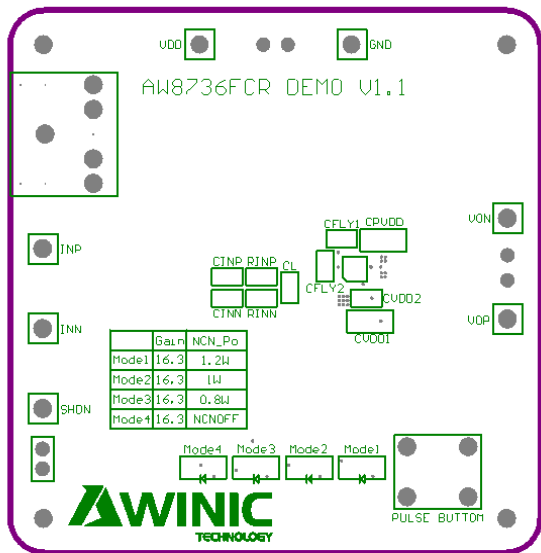

Top Layer

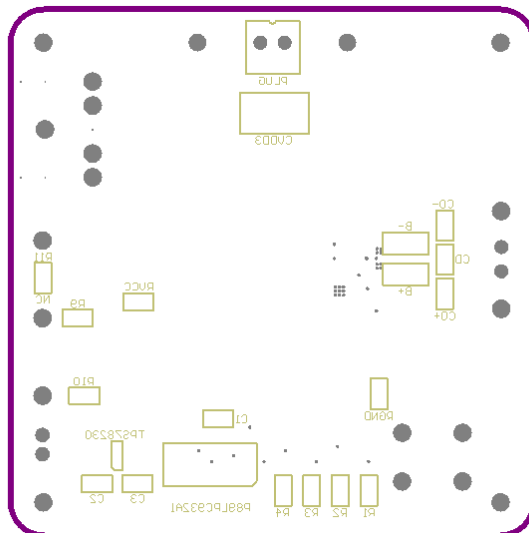

Bottom Layer

K

Demo

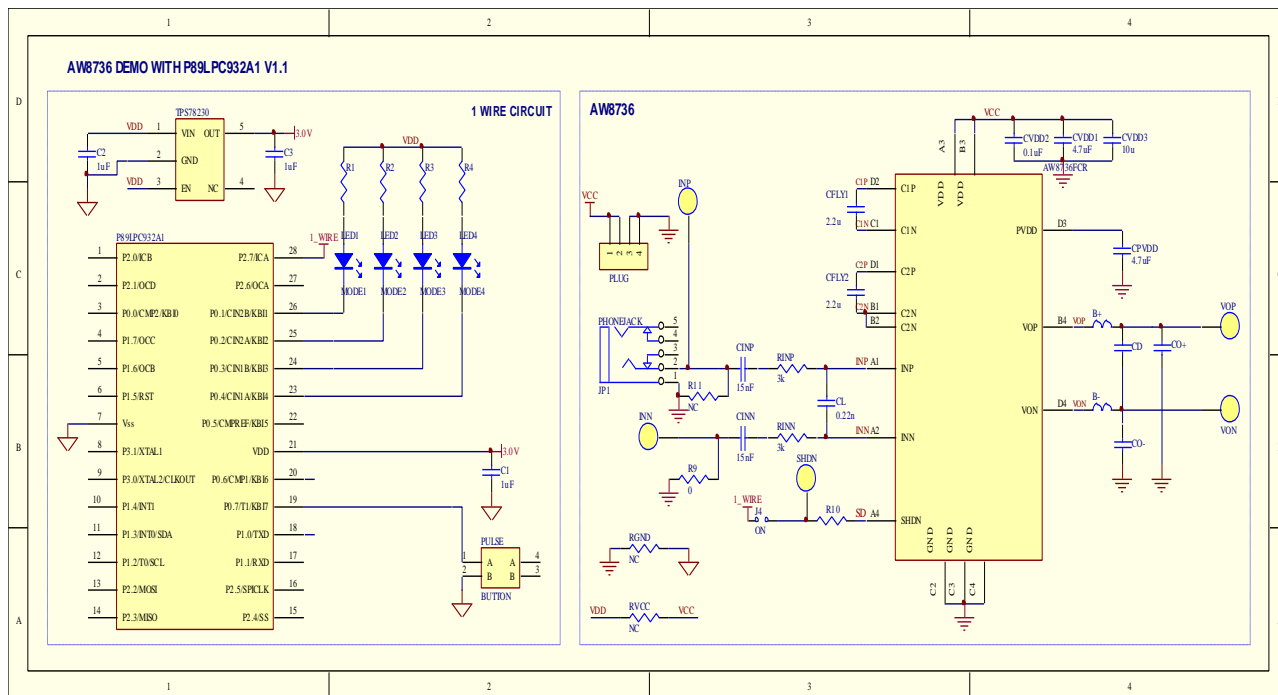

K

TOP VIEW

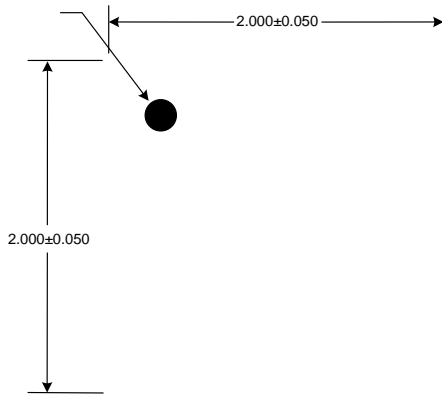

BOTTOM VIEW

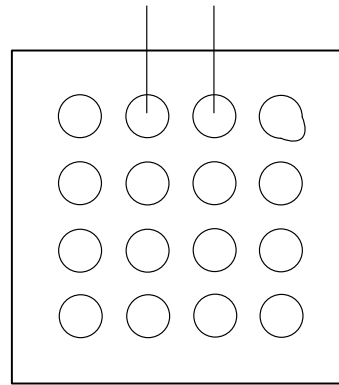

SIDE VIEW



K

V0.9	AW8736FCR		2012-10-31
V1.0	AW8736FCR		2012-11-30
V1.1	SNR		2013-01-05
V1.2	12 4ohm		2013-02-22
V1.3			2013-03-29
V1.4	1 CH 10V X5R X7R 2 3 4 3.3V~4.35V 5 12 6 NCN No-Crack-Noise Non-Crack-Noise 7 13 8 K-ChargePump " PVDD VDD 1.5 2 "		2013-04-19
V1.5	AW8736		2013-05-21